

## INTRODUCTION

Early timber floorboards used in Australia were usually square edged and butted together. This was called 'shot' edged. It is uncertain when tongue and groove floorboards were first introduced but certainly by the late 1820s some tongue and groove floorboards were being imported into Australia. These early imports were often of variable width, unlike shot-edged boards which were usually a constant width. This difference can help in identifying the type of boards, and therefore the repairs required, in early buildings.

Locally produced tongue and groove floorboards became available after about 1840 when steam powered milling machines became common. Both types of boards continued to be used through the nineteenth century.

Tongue and groove floorboards were most often milled from softwoods. Kauri pine, Baltic pine, Oregon pine and other pines are commonly seen as flooring material.

The use of the tongue and groove improved the ability of the floor to resist movement caused by moisture change which could lead to warping. Additionally, because there was always 'cover' in the gap between the boards, draughts were reduced. For modern repairers the tongue and groove adds to the difficulty of the repair as each board is 'locked' in and cannot be removed without either destroying a board or cutting a tongue or groove.

**'Shot' floorboards**



**Tongue and groove floorboards with loose tongues**



**Tongue and groove floorboards**



In addition to the problems and faults common to all timber floors, tongue and groove floorboards can also deteriorate when the tongue or groove collapses. Instead of replacing boards, the following repairs allow the retention of original material and thus retain significant historic material and reduce the use of limited resources. The suggested repairs do not aim to produce a floor that looks new, but result in workmanlike repairs and demonstrate respect for older fabric in heritage buildings.

## MINOR REPAIRS OF FLOORBOARDS

Minor holes and gouges can be filled with wood putty. Long splinters can be glued, if necessary pinned, and then filled with putty.

## REPAIRS

The following suggests two different types of repair, and the choice depends on the extent of damage. Resist the temptation to replace too many boards once work begins or because of a few gaps. These gaps may reduce in size during the next period of wet weather. Limit repairs and replacement to those boards which are structurally inadequate or hazardous.

### Repair 1: Where damage is limited

The following repair allows you to retain the floorboards in situ, and is very useful if you have boards made from a brittle timber which will split if you lift them. This repair can be used even if only a small amount of the board needs repair, but often looks best if carried out to the entire length of the board. It is also relevant where there are large gaps due to shrinkage. Note that it will alter the appearance of the floor but, if carried out well, it should not be unattractive.

- (a) In the gap between the boards cut down the side of the floorboard using a circular saw (5 inch or 7 inch with a thin blade). This will cut off the remainder of the damaged tongue. It may be necessary to set up a guide before cutting by gently tacking a straight edge to the floor for the saw to run against. Ensure the saw depth is set so that it cuts through the floorboard only and not through the joists below. You must finish the cut by hand, either with a handsaw or a sharp chisel, otherwise you are likely to overrun and cut into the next board.
- (b) Cut the remainder of the groove or damaged edge off the adjacent board in the same manner.
- (c) Insert a strip (sometimes called a 'slip') of timber in the gap created. The strip should be of the same timber and section as the existing, and be fully seasoned. The strip will need to span the joists below. Note that smaller areas of repair which cannot span between joists can be done as dovetail and tapered splices (shown in illustration 3).

- (d) Additionally, if the damage to the board is not through the full depth, it is possible to rout out the top surface and fix a patch as shown in illustration 2. The patch should be angled at the ends (in section).

Illustration 2

Tongue and groove board with split in the groove

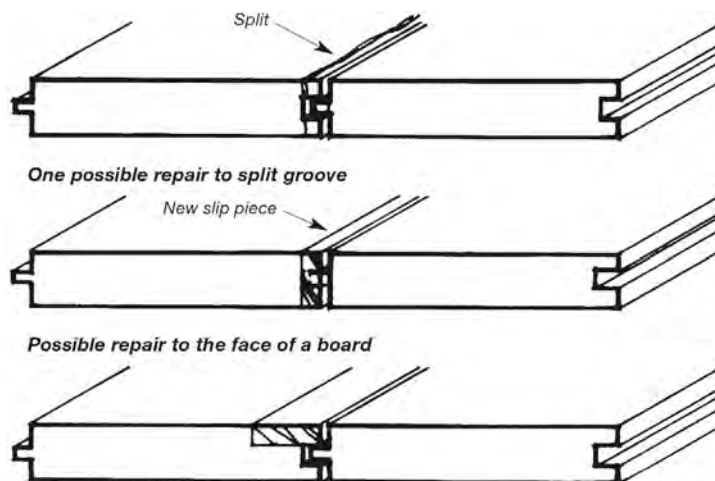
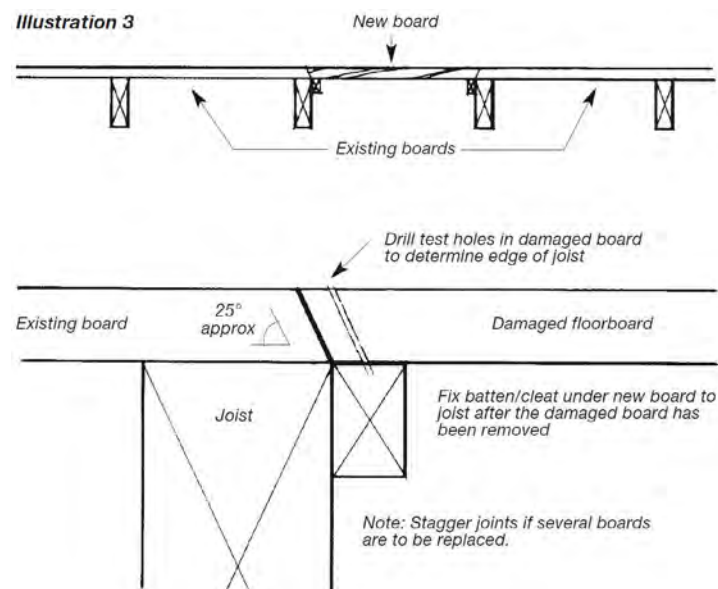

Illustration 3



- (e) Finish the new strip to match the remainder of the floor. It may also need to be stained/coloured to match. Avoid staining if possible, as the two timbers will then age differently. Remember that new sections of timber often achieve the same colour as the original material with time once the finish has been applied.

**Repair 2: Where damage is extensive**

The following repair can be used where damage is extensive, but cannot be used where the timber is brittle and will split if lifted – even if lifted with great care. It may also be difficult to lift and re-lay boards across a floor that has warped or settled differentially over time. This unevenness may be one of the pleasant qualities of age of a historic building and should not be removed as a matter of course.

- (a) Lift the floorboards over the damaged area. Lifting the first board is the most difficult operation. It is usually possible to cut the tongue off one board as described above and ease it up by inserting a wedge, such as board-faced chisel. The adjacent board against which you are forcing the wedge should be protected with some carpet or a thin sheet of hardened steel. A metal cutting reciprocating saw can be used to cut nails when the floorboard has been eased up from the joist, if necessary. Depending on the fixings, it may also be possible to ‘punch’ the nails through the boards using a fine punch that has been ground to the nail size for the depth of the floor. Note that either method of treating the fixings will enlarge the nail holes. Additionally, punching nails shouldn’t be attempted unless there are softwood joists.
- (b) Cut off the tongue and groove to the damaged board. If the tongue and groove on adjacent boards are intact, retain these sound boards. Re-lay the boards starting on one side of the room or lifted section. Insert new boards when you run out of original boards. The new boards may need to have the last tongue or groove cut off to fit (see illustration 4) and it may not be exactly the same width as the remainder. This variation has to be accepted.
- (c) Where multiple boards are to be replaced in a large patch, match the original width and stagger the joints at the end of boards over several joists to reduce the visual impact.
- (d) Cutting the boards between existing joints can be achieved as shown in illustration 3.

**Illustration 4**

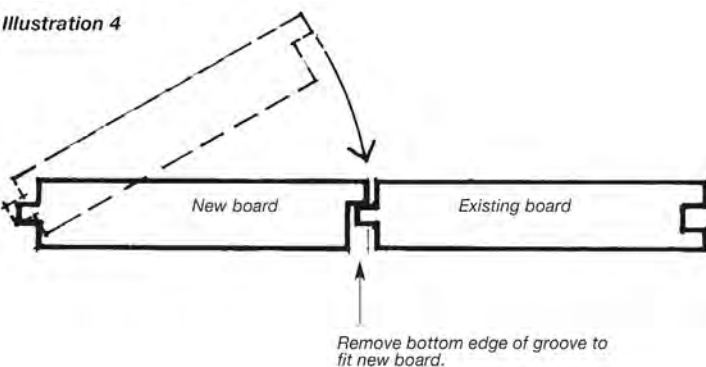

- (e) Finish the repair with the same finish as the remainder of the floor.

**SOME WARNINGS**

- (a) Sometimes old floors were fixed with hidden nails (see illustration 5). This is usually found on very fine floors used for entertaining and was done so that fixing positions did not impinge on the visual effect of a polished smooth surface. It is also the normal method of fixing narrow hardwood boards in England and America, and may have been used here by craftsmen trained in those traditions. If you cannot find fixing positions this will be the case and great care should be exercised in determining how to repair. The nails cannot be removed except possibly by drilling them out. Another variation was to cover the nails with wooden plugs matching the adjacent timber.
- (b) Note that there can be a wide variation in the width and thickness of milled floorboards. Take care in purchasing timber and in cutting to fit. The end of floorboards may not be square and a template may help to fit the new board. This can be checked by placing a set square over the end of the existing board. The replacement board can be ‘scribed’ or cut to match. You may also need to cut a board to accommodate a change in width of a board as you pass an adjacent joint.
- (c) Note that if oiled finishes such as tung oil are maintained, they will not require total removal for repair like polyurethanes. The sanding process to reapply a film forming finish like polyurethane removes up to 2-3 mm of timber each time. A tongue and groove floor can only be sanded a few times before the groove becomes exposed or the board loses its structural integrity. Historic timber floors should not be coated with polyurethane for this reason.
- (d) If floorboards need to be taken up for inserting electrics and/or other services, it is advisable that a joiner or carpenter carefully take up the floor ahead of the electrician starting work. Joiners and carpenters experienced in working on old buildings have the necessary skills and tools to carry out the work described above. Use the right tradesman for the work.

**Illustration 5**

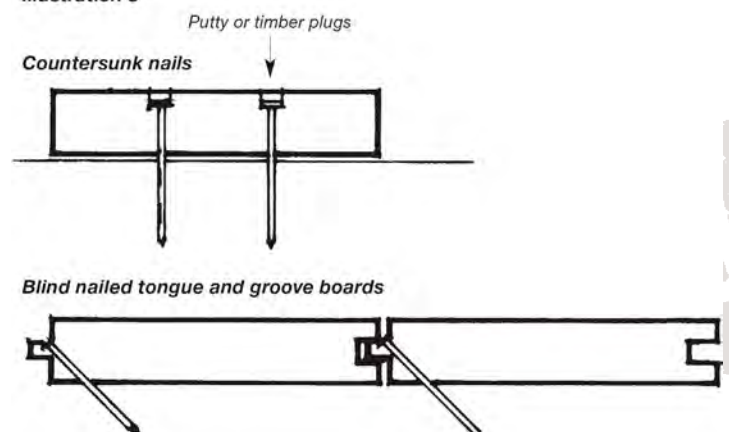

## Further Reading

NSW National Parks and Wildlife Service 1995, Guide to Building Conservation Works, NSW National Parks and Wildlife Service, Sydney.

Leeke, J. 1993, 'Fixing Hardwood Floors: How to Remove and Replace Tongue and Groove Floorboards', The Book of Interior Renovation, Dovedale, Gloucester, Massachusetts.

[Copy held in NSW Heritage Office Library. Note that American publications refer to a subfloor. This was another layer of boards below the finished floorboards to which they were fixed. It was probably done for climactic reasons, but also reflected the wealth of timber available. Buildings in Australia were not normally constructed this way, as floorboards were normally fixed directly to the structural floor joists.]

Poore, Patricia 1988, 'Fixing Old Floors; Repairing and Replacing Floorboards', The Old House Journal on Interior Restoration, The Old House Journal Corporation, USA. [Copy held in the NSW Heritage Office Library]

Bootle, Keith R. 1983, Wood in Australia – Types, Properties and Uses, McGraw-Hill, Sydney.

Bootle, Keith R. nd, Finishes for Timber Surfaces, Technical Publication No. 22, The Forestry Commission of New South Wales, Sydney.

## Acknowledgements

This publication was produced in accordance with resource-sharing arrangements approved by New South Wales Heritage Office.



**DISCLAIMER:** Any representation, statement, opinion or advice expressed or implied in this publication is made in good faith but on the basis that the State of Western Australia, its agents and employees are not liable (whether by reason of negligence, lack of care or otherwise) to any person for any damage or loss whatsoever which has occurred or may occur in relation to that person taking or not taking (as the case may be) action in respect of any representation, statement or advice referred to above.

For further information, please contact

Heritage Council of WA  
Locked Bag 2506  
Perth WA 6001  
T: (08) 6551 8002  
FREECALL (regional): 1800 524 000  
E: [info@dplh.wa.gov.au](mailto:info@dplh.wa.gov.au)  
W: [www.dplh.wa.gov.au](http://www.dplh.wa.gov.au)